

# The Effect of Silver-Zinc Zeolite Incorporation on Some Properties of Condensation Silicone Impression Material

Rehab A. Al-Azawi, B.D.S., H.D.D. <sup>(a)</sup>

Widad A. Al-Naqash, B.D.S., H.D.D., M.Sc. <sup>(b)</sup>

## ABSTRACT

**Background:** elastomeric impression materials are indicated when a high degree of accuracy is required, due to their excellent properties like details reproduction, dimensional stability and tear strength but with main two disadvantages those are their hydrophilicity as well as the absence of antibacterial activity. This study aimed to evaluate the effect of incorporation of 0.5% wt Ag-Zn zeolite into condensation silicone through the following tests; setting time, dimensional stability, reproduction of details, wettability, and hardness .

**Materials and methods:** one hundred specimens were constructed of condensation silicone, divided into two groups for the first 50 specimens one 0.5% by wt Ag -Zn zeolite was added, keeping the other fifty specimens without addition. Then each group further subdivided into five subgroups according to the conducted test. The tests performed were; setting time, dimensional stability, reproduction of details, hardness and wettability.

**Results:** A statistically non-significant effect on the setting time and reproduction of details tests was observed, combined with a highly significant increase of wettability of condensation silicone after incorporation of 0.5% wt Ag-Zn zeolite with non-significant increase of dimensional change of condensation silicone following incorporation of 0.5% wt Ag-Zn zeolite. Hardness test results showed statistically significant increase following the addition of Ag-Zn zeolite.

**Conclusion:** Ag-Zn zeolite incorporated into condensation silicone, improved wettability which determine the extent to which an impression material replicates the structures of the oral cavity and production of bubble-free gypsum die. It also showed a statistically significant increase in the hardness of condensation silicone impression material, and had no effect on setting time, reproduction of details and dimensional stability.

**Key words:** Condensation silicone impression materials, Antimicrobial agent, Ag- Zn Zeolite, wettability. (J Bagh Coll Dentistry 2016; 28(4):22-27)

## INTRODUCTION

Elastomeric impression materials include a group of synthetically polymerized impression materials that are chemically cross-linked when set and could be stretched and recover to their original dimensions. There are three types based on the chemical backbone of polymer chains: polysulfide, polyether, and silicone; the condensation and addition <sup>(1)</sup>.

Condensation silicone impression materials are widely used nowadays is supplied in a two consistencies light and putty-like. The curing of this material involves a reaction of tri- and tetra-functional alkyl silicates in the presence of stannous octoate as a catalyst. The material sets by cross-linking between terminal groups of the silicone polymers and the alkyl silicate to form a three-dimensional network, the ethyl alcohol as a byproduct. Its subsequent evaporation accounts for much of the contraction that takes place in the setting impression <sup>(1,2)</sup>.

Nowadays infection control takes interest in order to prevent cross infection between the patients and dental staff. The threat of infections could be transferred by blood, saliva, and/or plaque is a potential occupational risk as they include pathogenic microorganisms <sup>(3)</sup>.

The incorporation of zeolite as filler in polymers was reported in literatures and proved that it enhanced the antibacterial activity of these polymers. Silver ion exchanged zeolites have excellent antibacterial activity and therefore have a potential in the medical field to enhance antimicrobial properties.<sup>(4)</sup>

The present study was conducted to assess the incorporation of Ag-Zn zeolite into condensation impression material and evaluate its effects on their properties

## MATERIALS AND METHODS

One hundred specimens of condensation silicone were prepared, divided into two groups; fifty specimens control (without addition) and fifty experimental specimens (with addition of 0.5% Ag-Zn zeolite) with fifty specimens, then each group was subdivided according to the test conducted; each subgroup containing ten specimens for each test.

The percentage 0.5 % is chosen in this study as this percentage representing the minimum percentage as an effective bactericidal agent as proved by many authors <sup>(5,6)</sup>.

### Physical and mechanical tests:

#### 1- Dimensional change test:

The test block and ring mold were fabricated for this study (ADA/ANSI) specification no.19. Consisted of two parts; a circular stainless steel

<sup>(a)</sup>M.Sc. student. Department of Prosthodontics. College of Dentistry, University of Baghdad.

<sup>(b)</sup>Professor. Department of Prosthodontics. College of Dentistry, University of Baghdad.

block, and a hollow stainless steel ring was used to retain and confine the impression material.

Three vertical lines a 25 mm length and of 25 mm diameter (line a 50  $\mu$ m, line b 25  $\mu$ m, line c 75  $\mu$ m). Two additional horizontal lines 25 mm apart from each other were engraved perpendicular to the vertical lines (line d1 and d2) as in (fig. 1)

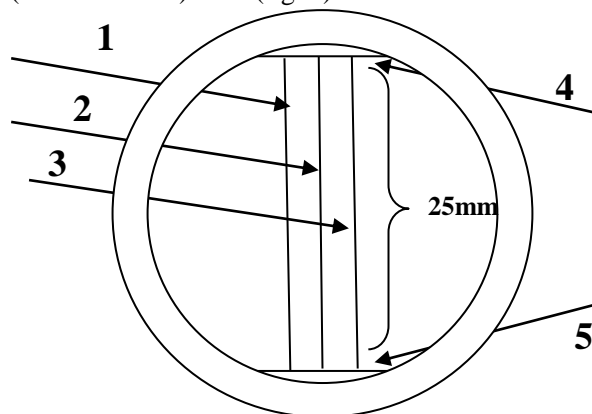

**Figure 1: The lines of the test mold:**  
1 line a (50  $\mu$ m thick.), 2 line b(25  $\mu$ m thick.), 3 line c (75  $\mu$ m thick.), 4 line d1(50  $\mu$ m thick), 5 line d2 (50  $\mu$ m thick).<sup>(7)</sup>

### 2-Reproduction of details test

The same mold used for dimensional change test (fig. 1) was again used for this test. Following the separation and washing of the specimen an estimation by three independent examiners was carried on to assess the reproduction of details by examining the continuity of the line b (25  $\mu$ m) on the impression surface. Where line b is the smallest in diameter among the die lines, so if it is clearly reproduced the other larger lines would be already reproduced<sup>(8-10)</sup>.

### 3-Setting time test

Vicat penetrometer has been used, with a needle of 3-mm diameter and a total weight of 300g. A metal ring of 8 mm high and diameter of 16 mm was filled with newly mixed material and positioned on the penetrometer base. Then needle was applied to the surface of the impression material for 10 sec. and a reading was recorded. This step was repeated every 30 sec.

The initial set is that time when the needle no longer penetrates the specimen completely to the bottom of the specimen. While the final set is the first of three non-maximum identical penetration readings<sup>(2)</sup>.

### 4-Wettability test:

Wettability assessed by measuring the advancing contact angle of liquid on the surface of the set impression material. Specimens were poured in cylindrical metal mould. A drop of distilled water falling down above a set specimen and after one minute measure the angle between the surface of the drop and the surface of specimen by dino-lite microscope<sup>(11)</sup>.

### 5- Hardness test:

The specimens made for this test by using a cylindrical mold. Then the hardness of condensation silicone impression material was tested by shore A hardness durometer instrument.

This device was firmly grasped and insert its indenter in the set specimen as shown in the (fig.2) the specimen was placed on a stable bench where the readings were recorded on the device screen. Two readings were obtained, the first represented the hardness 1.5 minutes after setting, where the second reading was for the hardness after 2 hours.<sup>(12)</sup>

Four specific indentations were measured each time distributed it in a 90° manner at a location 12 mm from any edge and at least 6 mm from any previous indent (the same selected area of each specimen), measurements followed ASTM D2240 05 specification for Shore A hardness measurements. The average of the four readings in order to measure the whole surface of the specimen<sup>(13)</sup>.



**Figure 2: Hardness sample with the sites of penetration**

## RESULTS

### 1- Dimensional change test:

Mean values, number of specimens, standard deviation, t-test, and p-values of dimensional change test for control and experimental groups of

condensation silicone are presented in table 1, table 2 and fig. 3.

The results of dimensional test indicated non-significant difference between experimental and control groups which exhibited a mean values - 0.877 and -0.917 respectively.

**Table 1: descriptive data of dimensional change test for control and experimental groups**

Group	N	Mean%	SD
Control	10	-0.917	0.47
Experimental	10	-0.877	0.4

**Table 2: t-test and p-value for dimensional change test**

t-test	p-value	Sig.
-0.2	0.84	NS

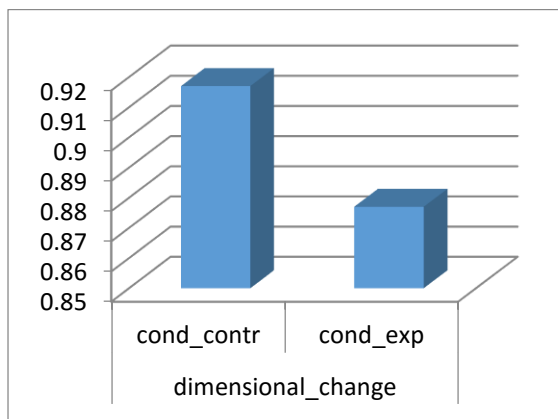

**Figure 3: Bar chart of dimensional change for condensation silicone**

**2-reproduction of details**

The results of reproduction of details test are listed in table 3, showed the similarity in descriptive data for both groups; control and experimental.

**Table 3: reproduction of details results for the control and experimental groups.**

Group	N	Satisfactory	Unsatisfactory
Control	10	100%	0%
Experimental	10	100%	0%

**3- Wettability**

Mean values, number of specimens, standard deviation, t-test, and p-values of wettability test, are presented in tables 4, 5 and fig4.

The results indicated very clear and highly significant difference between means of the experimental (62.27) and control (72.84) groups.

**Table 4: Descriptive data of wettability test for control and experimental groups.**

Group	N	Mean°	SD
Control	10	72.84	1.28
Experimental	10	62.27	2.38

**Table 5: t-test and p-value for wettability test**

t-test	p-value	Sig.
12.346	0.00	HS

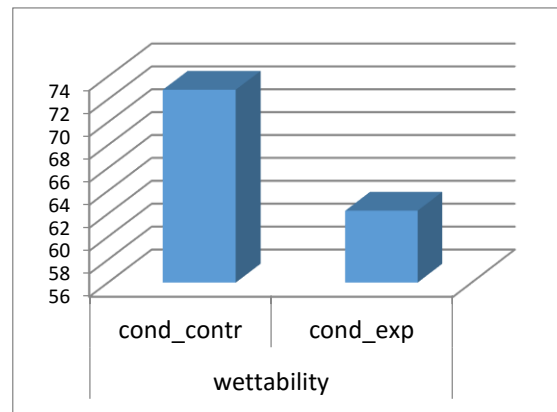

**Figure 4: Bar chart for wettability test.**

**4-Setting time test:**

Mean values, number of specimens, standard deviation, t-test, and p-values of setting time test, are presented in table 6, table 7 and fig. 5.

These results indicated a similar mean values for both groups; experimental and control, which is (216 seconds).

**Table 6: Descriptive data of setting time test for control and experimental groups**

Group	N	Mean(sec)	SD
Control	10	216	12.64
Experimental	10	216	12.64

**Table 7: t-test and p-value for setting time test**

t-test	p-value	Sig.
0.00	1	NS

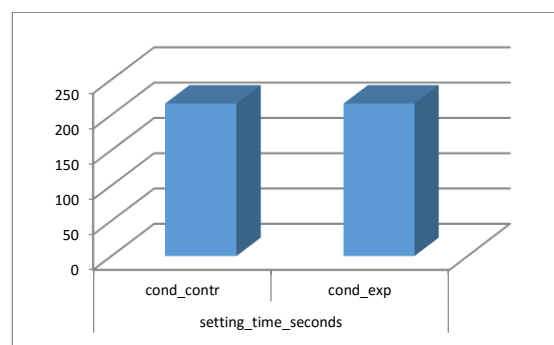
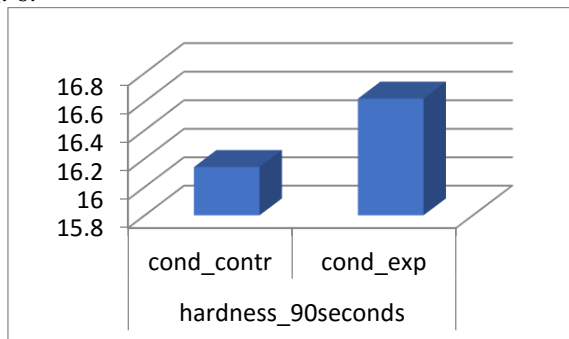

**Figure 5: Bar chart for setting time test.**

**5-Hardness test:**

**A- After 1.5 minute:**

Mean values, number of specimens, standard deviation, t-test, and p-values of hardness test at 1.5 minute, are presented in table 8, table 9 and fig. 6.



**Figure 6: Bar chart for hardness at 90 second**

Their results indicated a non-significant difference between experimental and control means which are 16.62 and 16.14 respectively

**Table 8: Descriptive data of hardness test at 90 sec. for control and experimental groups.**

Group	N	Mean(°)	SD
Control	10	16.14	1.58
Experimental	10	16.62	0.94

**Table 9: t-test and p-value for hardness test at 90 sec.**

t-test	p-value	Sig.
-0.595	0.42	NS

**B-Hardness test at 2 hour**

Mean values, number of specimens, standard deviation, t-test, and p-values of hardness test at 1.5 minute, are presented in table 10, table 11 and fig. 7.

The results indicated very clear and highly significant difference between means of the experimental and control groups, which are; 35.04 and 31.39 respectively.

**Table 10: Descriptive data of hardness test at 2hr. for control and experimental groups.**

Group	N	Mean(°)	SD
Control	10	31.39	1.77
Experimental	10	35.04	0.78

**Table 11: t-test and p-value for hardness test at 2hr.**

t-test	p-value	Sig.
-0.82	0.00	HS

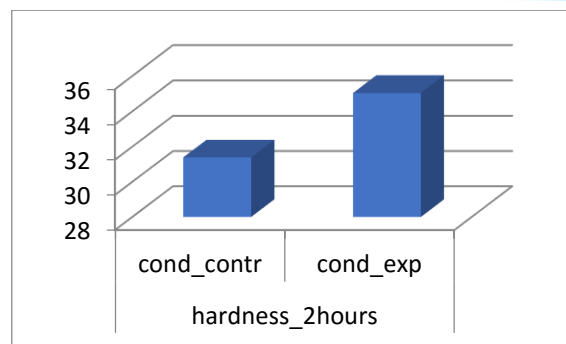

**Figure 7: Bar chart for hardness at 2 hour**

**DISSCUSION**

Zeolite was selected as a vehicle for antimicrobial cations because of its characteristics, including prolonged antimicrobial activity, non-toxicity and lack of odor or flavor<sup>(14-16)</sup>.

Zeolite type X was used in this study due to the fact that zeolite X has got an excellent ionic conductivity as well as superior hydrophilicity. As zeolite X has low Si/Al ratio where the cation concentration, ion exchange capacity and hydrophilicity are inversely proportional to that ratio<sup>(15-17)</sup>

Hydrophilicity is a beneficial attribute to prevent air bubbles formation within gypsum replica<sup>(18)</sup>.

Sliver and zinc ion as the cations of choice to be used in this study because they proved to possess strong antibacterial and antifungal activity<sup>(19,20)</sup>. The concentration of 0.5 % selected in this study was optimized as this percentage representing the minimum percentage as an effective bactericidal agent<sup>(5,6)</sup>.

The results of dimensional change test in this study shows that the incorporation of Ag-Zn zeolite into condensation silicone because a non-significant change in the dimensional change of condensation silicone, this could be due to that the zeolite slightly decreases the evaporation of ethanol as by product. Another explanation is that it could be due to that the condensation silicone already contain silica in its basic ingredients in a percentage between (35-70%) so the added 0.5% by wt well probably has no sensible effects on condensation properties<sup>(12,21)</sup>.

Concerned with reproduction of details test it was noticed that the experimental group of condensation silicone showed almost identical results with those of control group, as an explanation it could be due to the small particles of incorporated zeolite in a range of (0.5 μm) which was in accordance with the requirements of ADA/ANSI specification no. 19 for elastomeric impression material<sup>(7,8,21)</sup>. Also it could be due to





24. Park YJ, Kim HO, Kim MK, Han HS, Song HJ, Vang MS. Effects of zeolite filler in surfactant-containing silicone rubber impression materials. 86<sup>th</sup> IADR, 2008.

25. Bussaya R. The development of rubber compound based on natural rubber and ethylene propylene die ne monomer for playground rubber material. A master thesis, Kasetsart University, 2007.